

NK-300VR

FULLY HYDRAULIC TRUCK CRANE

[SPECIFICATION]

■ CRANE

Description	Truck crane with maximum lifting capacity 30 ton
Model	NK-300VR

● Specification

Maximum rated lifting capacity	10.6 m Boom	30,000 kg × 3.0 m (Parts of line : 10)
	14.5 m Boom	23,000 kg × 4.0 m (Parts of line : 8)
	18.4 m Boom	16,000 kg × 5.0 m (Parts of line : 8)
	22.3 m Boom	12,000 kg × 7.0 m (Parts of line : 4)
	26.2 m Boom	12,000 kg × 7.0 m (Parts of line : 4)
	30.1 m Boom	9,500 kg × 8.0 m (Parts of line : 4)
	34.0 m Boom	7,500 kg × 9.0 m (Parts of line : 4)
	8.3 m Jib	3,400 kg × 75° (Parts of line : 1)
	13.8 m Jib	2,200 kg × 78° (Parts of line : 1)
Rooster	3,400 kg (Parts of line : 1)	
Boom length	10.6 m — 34.0 m (4 section)	
Fly jib length	8.3 m , 13.8 m (2 section)	
Maximum lifting height	34.0 m (Boom)	
	48.0 m (jib)	
Hoisting line speed (winch up)	Main winch	105 m / min. (at 4th layer)
	Auxiliary winch	91 m / min. (at 2nd layer)
Hoisting hook speed (winch up)	Main winch	(Parts of line; 10) : 10.5 m / min. (at 4th layer)
	Auxiliary winch	(Parts of line; 1) : 91.0 m / min. (at 2nd layer)
Boom derricking angle	-3° — 82°	
Boom derricking time	58 s (-3° — 82°)	
Boom extending time	116 s (10.6 m — 34.0 m)	
Slewing speed	2.3 min ⁻¹	
Tail slewing radius	3,370 mm	

● Equipment and structure

Boom type	Box-shaped, 4-section hydraulically telescopic type (Boom sections 3 / 4 simultaneously operated)	
Jib type	2 sections (2nd section of draw-out type, 3-step inclination type (offset angles 5°, 25° and 45°))	
Boom extension/retraction equipment	Two hydraulic cylinders and wire ropes used together	
Boom derricking/lowering equipment	One hydraulic cylinder of direct acting type with pressure-compensated flow control valve	
Winch system Main & Auxiliary winches	Driven by axial plunger type hoisting motor through built-in gear reduction. Controlled independently by respective operating lever. Equipped with automatic brake.	
Slewing equipment	Ball bearing type	
Wire rope for hoisting	Main winch	Diameter: 16 mm × Length: 190 m
	Auxiliary winch	Diameter: 16 mm × Length: 110 m

● Hydraulic system

Oil pump	4 section gear type	
Hydraulic motor	Hoisting motor	Axial plunger type
	Slewing motor	Axial plunger type
Control valve	3 position 4 way double acting with integral check and relief valves	
Cylinder	Double acting type	
Oil reservoir capacity	400 L	

● Safety devices

	ACS (Automatic crane system with voice alarm), Boom falling prevention device, Winch hoisting limiter, Winch drum lock device, Winch drum turning indicator device, Automatic winch brake, Winch drum roller, Hydraulic safety valve, Outrigger lock device, Joystick control safety stop system, Slewing lock device
--	---

● Standard equipment

	Fly jib, Rooster sheave, Independent two winches control system, Hooks (30 ton, 3.4 ton), Full size fender, Large size steps, 3 working lights, Outrigger sheet, Cigar lighter, Ashtray, Cab floor mat, Tool kit
--	--

● Optional equipment

	Winch over-unwinding device, Front jack, Hydraulic oil cooler, Cab heater, Cab cooler, Fan, Radio AM FM, Fire extinguisher
--	--

■ CARRIER

Maker and model	FAW CA5325JQZ
-----------------	---------------

● Specification

Maximum traveling speed	73 km/h
Gradeability (tan θ)	35 % (theoretically computed at G.V.W. = 30900 kg)
Minimum turning radius (center of extreme outer tire)	11.5 m

● General dimensions

Overall length	approx. 12,650 mm	
Overall width	approx. 2,500 mm	
Overall height	approx. 3,800 mm	
Wheel base	5,825 mm (4,475 mm+1,350 mm)	
Treads	Front	2,071 mm
	Rear	1,847 mm
Outriggers	Type	Hydraulic H-beam type (with float and vertical cylinder in single unit)
	Extended outriggers	6,100 mm (Fully extended)
		4,100 mm (Intermediately extended)
		2,080 mm (Fully retracted)
Gross machine weight	Gross weight	approx. 30,900 kg
	Front weight	approx. 6,950 kg
	Rear weight	approx. 23,950 kg

● Engine

Model	FAW CA6DL1-29E3 (EURO-III)
Type	6-inline, 4cycle, turbo charged, direct injection water cooled, diesel with intercooling
Piston displacement	7.7 L
Max. power	213 kW / 2,300 min ⁻¹
Max. torque	1,150 N·m / 1,600 min ⁻¹

● Equipment and structure

Drive system	6 × 4	
Clutch	Single dry plate, hydraulic control with air booster	
Transmission	Manual transmission type	
Number of speeds	8 forward & 1 reverse speed	
Axles	Front	Reverse "ELLIOT" type
	Rear	Full floating type with hub reduction
Suspension	Front	Leaf springs with shock absorber
	Rear	Equalizer beams and torque rods with leaf springs (with lockout device)
Brakes	Service	2 circuit air brake, 6 wheels internal expanding type
	Parking	Spring loaded brake
	Auxiliary	Exhaust brake
Steering	Type	Ball nut type with power booster
Tire size	Front	12R22.5(16 PR)
	Rear (dual tire)	12R22.5(16 PR)
Fuel tank capacity	300 L	
Seating capacity	2 persons	
Battery	(12V-6-QAW-180) × 2	

● Standard equipment

	Towing hook (front and rear, eye type), Spare tire & wheel, Air dryer, Radio AM FM, Cigar lighter, Ashtray, Cab cooler, Cab heater
--	--

- Stow the hooks in place before traveling.
- Before you use this machine, read the precautions in the instruction manual thoroughly to operate it correctly.
- KATO products and specifications are subject to improvements and changes without notice.

10.6 m — 34.0 m Boom

Outriggers fully extended with front jack		-360° full range					
Outriggers fully extended without front jack		-over side and over rear					
Working radius (m)	10.6 m Boom	14.5 m Boom	18.4 m Boom	22.3 m Boom	26.2 m Boom	30.1 m Boom	34.0 m Boom
2.5	30.00	23.00	16.00				
3.0	30.00	23.00	16.00				
3.5	26.50	23.00	16.00	12.00			
4.0	24.00	23.00	16.00	12.00	12.00		
4.5	22.00	21.50	16.00	12.00	12.00		
5.0	20.10	19.80	16.00	12.00	12.00	9.50	
6.0	16.50	16.10	15.00	12.00	12.00	9.50	7.50
7.0	13.70	13.20	13.10	12.00	12.00	9.50	7.50
8.0	11.40	11.10	11.00	11.00	10.55	9.50	7.50
8.5	10.30	10.30	10.20	10.25	9.95	8.95	7.50
9.0		9.40	9.30	9.50	9.40	8.40	7.50
10.0		7.60	7.50	8.00	8.30	7.50	6.90
12.0		5.30	5.10	5.60	5.90	6.10	5.70
14.0			3.65	4.05	4.30	4.50	4.70
16.0			2.65	3.00	3.30	3.45	3.60
18.0				2.25	2.50	2.70	2.80
20.0				1.65	1.90	2.10	2.20
22.0					1.45	1.60	1.70
24.0					1.05	1.25	1.35
26.0						0.90	1.00
28.0						0.65	0.75
30.0							0.55
31.0							0.45
Standard hook	for 30 ton						
Hook mass	300 kg						
Parts of line	10	8		4			
Critical boom angle	—	—	—	—	—	—	—

(Unit: Metric ton)

Outriggers intermediately extended without front jack		-360° full range					
Outriggers fully extended without front jack		-over front					
Working radius (m)	10.6 m Boom	14.5 m Boom	18.4 m Boom	22.3 m Boom	26.2 m Boom	30.1 m Boom	34.0 m Boom
2.5	25.00	23.00	16.00				
3.0	25.00	23.00	16.00				
3.5	25.00	23.00	16.00	12.00			
4.0	22.40	22.20	16.00	12.00	12.00		
4.5	17.45	17.30	16.00	12.00	12.00		
5.0	14.15	14.00	13.90	12.00	12.00	9.50	
6.0	10.00	9.85	9.80	10.20	10.40	9.50	7.50
6.5	8.65	8.50	8.40	8.85	9.10	9.10	7.50
7.0	7.55	7.40	7.30	7.70	8.00	8.20	7.50
8.0	5.90	5.75	5.65	6.05	6.30	6.50	6.65
8.5	5.30	5.10	5.00	5.40	5.65	5.85	6.00
9.0		4.55	4.50	4.85	5.10	5.30	5.45
10.0		3.70	3.60	3.95	4.15	4.35	4.50
12.0		2.30	2.20	2.60	2.90	3.10	3.20
13.0			1.70	2.10	2.35	2.55	2.70
14.0			1.25	1.65	1.90	2.10	2.30
15.0			0.90	1.30	1.55	1.75	1.90
16.0			0.65	1.00	1.25	1.45	1.60
17.0				0.75	0.95	1.15	1.30
18.0					0.75	0.95	1.05
19.0					0.55	0.70	0.85
20.0						0.55	0.65
Standard hook	for 30 ton						
Hook mass	300 kg						
Parts of line	10	8		4			
Critical boom angle	—	—	—	26°	37°	45°	51°

(Unit: Metric ton)

34 m Boom + 8.3 m Jib

Outriggers fully extended with front jack -360° full range						
Outriggers fully extended without front jack -over side and over rear						
Boom angle (°)	34 m Boom + 8.3 m Jib					
	Offset 5°		Offset 25°		Offset 45°	
	Working radius (m)	Load (ton)	Working radius (m)	Load (ton)	Working radius (m)	Load (ton)
82	6.8	3.40	9.5	2.20	11.4	1.30
79	9.3	3.40	11.9	2.20	13.5	1.30
77	11.1	3.40	13.4	2.15	14.9	1.30
75	12.8	3.40	14.8	2.05	16.2	1.30
72	14.6	3.05	17.0	1.95	18.3	1.25
68	17.7	2.45	19.7	1.80	20.8	1.20
64	20.3	2.05	22.2	1.60	23.2	1.15
63	20.9	1.95	22.8	1.55	23.7	1.15
61	22.1	1.70	24.1	1.50	24.9	1.14
60	22.8	1.55	24.6	1.40	25.4	1.13
57	24.4	1.25	26.2	1.14	27.0	1.10
55	25.5	1.07	27.2	0.97	28.0	0.94
50	28.0	0.71	29.7	0.64	30.1	0.64
46	30.0	0.48	31.4	0.44	31.8	0.43
44	31.0	0.37	32.3	0.34		
Standard hook	for 3.4 ton					
Hook mass	60 kg					
Parts of line	1					
Critical boom angle	42°		42°		44°	

34 m Boom + 13.8 m Jib

Outriggers fully extended with front jack -360° full range						
Outriggers fully extended without front jack -over side and over rear						
Boom angle (°)	34 m Boom + 13.8 m Jib					
	Offset 5°		Offset 25°		Offset 45°	
	Working radius (m)	Load (ton)	Working radius (m)	Load (ton)	Working radius (m)	Load (ton)
82	8.4	2.20	12.6	1.10	15.9	0.70
80	10.4	2.20	14.3	1.10	17.5	0.70
78	12.4	2.20	16.0	1.08	19.0	0.70
76	14.1	2.00	17.6	1.02	20.5	0.70
72	17.3	1.65	20.8	0.92	23.2	0.67
68	20.4	1.43	23.7	0.85	25.9	0.65
64	23.5	1.25	26.5	0.79	28.4	0.63
60	26.4	1.11	29.2	0.75	30.7	0.62
56	28.9	0.91	31.6	0.71	32.8	0.61
55	29.5	0.84	32.2	0.69	33.3	0.61
53	30.7	0.70	33.3	0.63	34.3	0.59
50	32.4	0.54	34.9	0.47	35.6	0.47
48	33.4	0.44	35.8	0.39	36.4	0.39
46	34.5	0.35	36.8	0.31	37.2	0.31
Standard hook	for 3.4 ton					
Hook mass	60 kg					
Parts of line	1					
Critical boom angle	44°					

661-75103000

34 m Boom + 8.3 m Jib

Outriggers intermediately extended without front jack -360° full range						
Outriggers fully extended without front jack -over front						
Boom angle (°)	34 m Boom + 8.3 m Jib					
	Offset 5°		Offset 25°		Offset 45°	
	Working radius (m)	Load (ton)	Working radius (m)	Load (ton)	Working radius (m)	Load (ton)
82	6.8	3.40	9.5	2.20	11.4	1.30
79	9.3	3.40	11.9	2.20	13.5	1.30
77	11.0	3.35	13.4	2.15	14.9	1.30
75	12.4	3.10	14.8	2.05	16.2	1.30
74	13.1	2.75	15.6	2.00	16.9	1.28
72	14.4	2.20	16.9	1.74	18.3	1.25
70	15.7	1.75	18.1	1.41	19.6	1.20
67	17.6	1.22	19.8	1.00	21.2	0.91
65	18.8	0.93	21.0	0.77	22.3	0.70
Standard hook	for 3.4 ton					
Hook mass	60 kg					
Parts of line	1					
Critical boom angle	63°					

34 m Boom + 13.8 m Jib

Outriggers intermediately extended without front jack -360° full range						
Outriggers fully extended without front jack -over front						
Boom angle (°)	34 m Boom + 13.8 m Jib					
	Offset 5°		Offset 25°		Offset 45°	
	Working radius (m)	Load (ton)	Working radius (m)	Load (ton)	Working radius (m)	Load (ton)
82	8.4	2.20	12.6	1.10	15.9	0.70
80	10.4	2.20	14.3	1.10	17.5	0.70
78	12.4	2.20	16.0	1.08	19.0	0.70
76	14.1	2.00	17.6	1.02	20.5	0.70
73	16.3	1.75	20.0	0.94	22.6	0.68
70	18.7	1.30	22.3	0.89	24.6	0.66
68	20.1	1.01	23.7	0.79	25.9	0.65
66	21.5	0.75	25.0	0.62	27.2	0.54
Standard hook	for 3.4 ton					
Hook mass	60 kg					
Parts of line	1					
Critical boom angle	64°					

Outriggers fully retracted (blocked on vertical cyls.) -360° full range	
Working radius (m)	10.6 m Boom
2.5	7.00
3.0	7.00
3.5	5.50
4.0	4.50
4.5	3.70
5.0	3.10
5.5	2.60
6.0	2.20
6.5	1.80
7.0	1.50
7.5	1.20
8.0	1.00
Standard hook	for 30 ton
Hook mass	300 kg
Parts of line	10

(Unit: Metric ton)

661-75104000

Precautions

1. The rated lifting capacities indicate the maximum load which can be lifted by this crane provided it is standing on firm, level ground. They include the mass of the hook and all other slings etc. The capacities enclosed with bold lines are based on the structural strength of the crane.
2. The working radii as given in the lifting capacity chart are the actual values including the deflection of the boom. Therefore, operate the crane based on the working radius. However, the working radii shown for jib operations are based on the values obtained when the boom is fully extended (34 m). If the boom is at any other length, jib operations should be performed on the basis of the boom angle only.
3. The rated lifting capacities for the rooster sheave are equivalent to the rated lifting capacities for the boom to a maximum of 3400 kg.
At all times the mass of all slings etc. in use (including the slings etc. attached to the boom) must be subtracted from the rated lifting capacity.
4. If the boom length exceeds the rated value, the rated lifting capacities for the rated boom length or for the one stage longer boom length should be referred to, and the crane should be operated within the smaller lifting capacity.
5. If you are working with the boom while the jib is mounted, 2200 kg plus the mass of the slings etc. should be subtracted from the rated lifting capacity. When performing the above operation, do not use the rooster sheave.
6. Critical boom angles for each boom length are shown on bottommost line of the lifting capacity chart. If the boom angle is lowered to less than the critical boom angle, the crane will tip over even if unloaded. Therefore, never lower the boom below these angles.
7. The standard number of parts of line for each boom length are indicated in the lifting capacity chart. If you work with a non-number of parts of line, take 29.4 kN (3 tf) as the maximum load on any part of the wire rope.
8. Frontward hoisting capacity with the outriggers fully extended is lower than sideward or rearward hoisting capacity. Great care should be taken when transferring from over side to over front since there is a danger of overloading.
9. Crane operation is permissible up to a wind speed of 10m/s.
Even in relatively light wind conditions, extra care should be taken when handling loads presenting large wind catching areas.
10. If you work with a load in excess of the rated lifting capacity or use incorrect working procedures, you are risking damaging the crane or tipping it over. In such cases, the crane will not be guaranteed.

WORKING RANGE

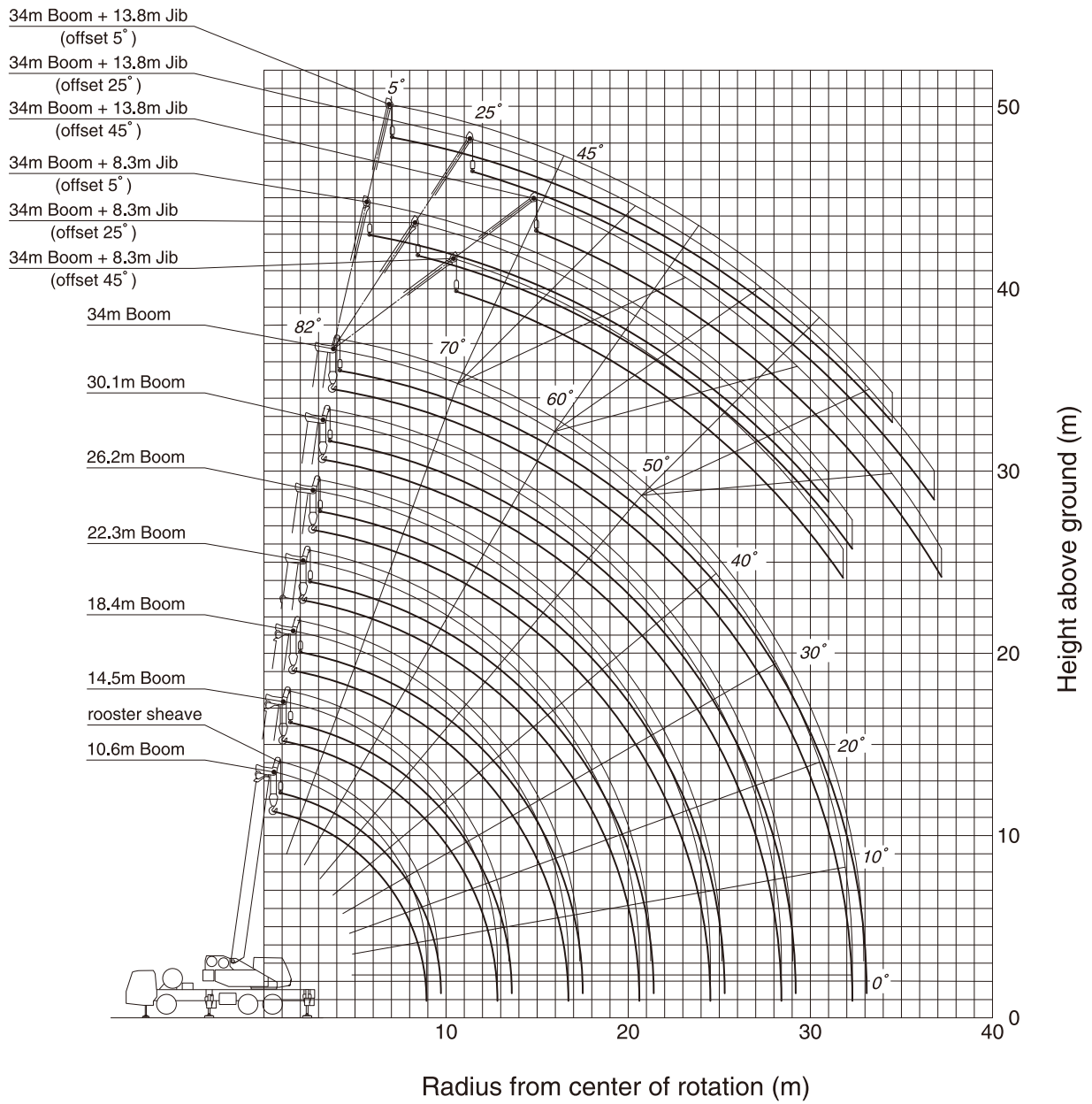

Note:

1. This diagram does not include deflection of Boom and Fly jib.
2. The outriggers are fully extended.

661-75107000

Minimum path width

● Right turn

● Left turn

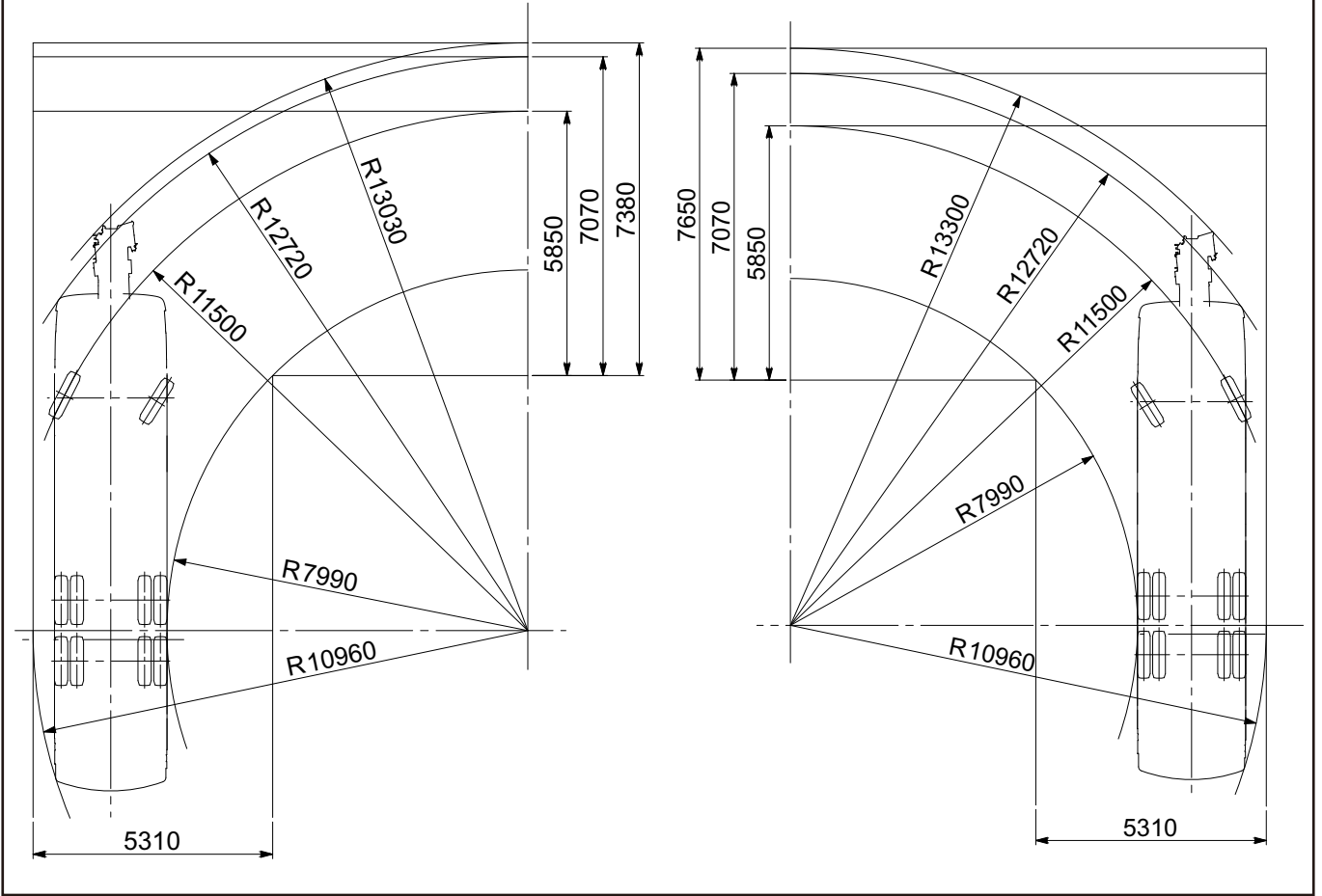

Overall view

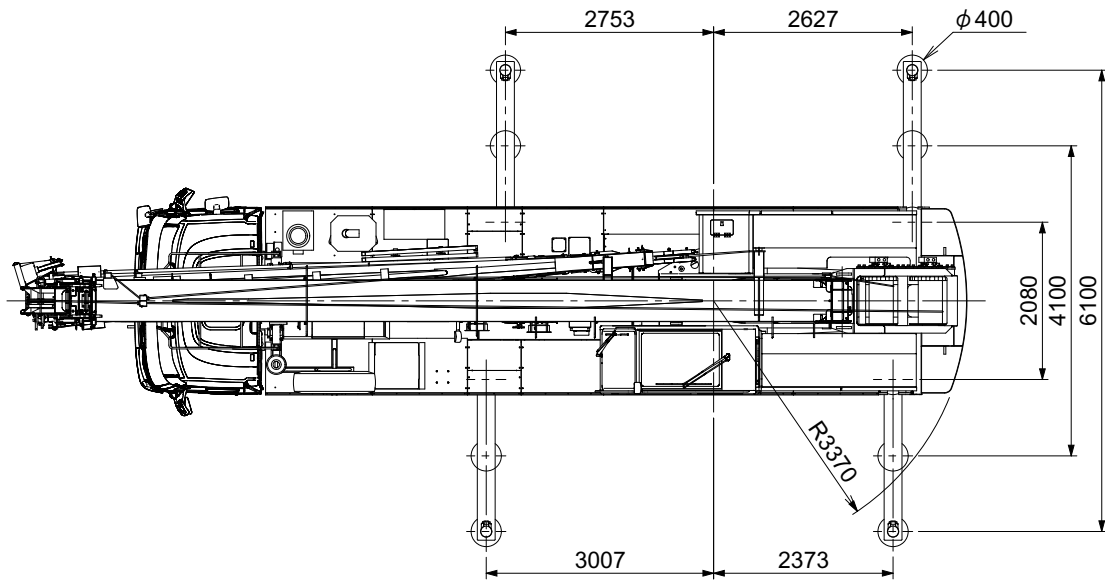

Reduced scale: 1/100 Unit (mm)

Overall view

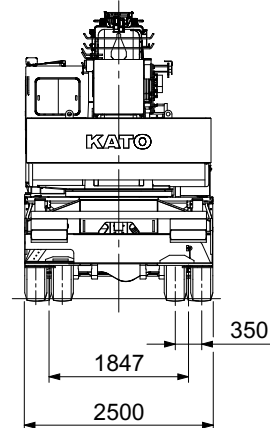
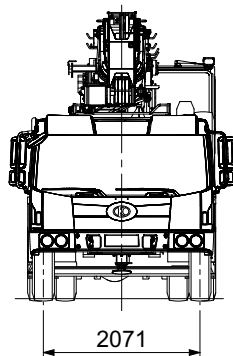
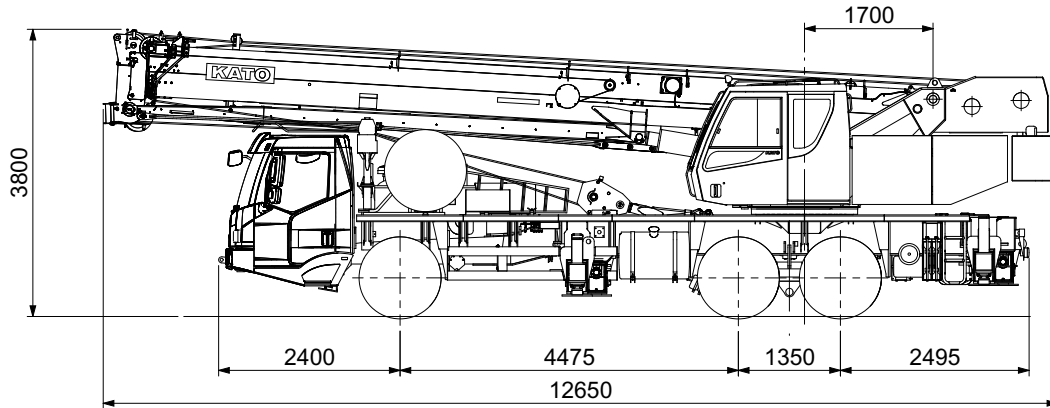

Reduced scale: 1/100 Unit (mm)

* KATO products and specifications are subject to improvements and changes without notice.

Address inquiries to:

KATO
KATO WORKS CO.,LTD.

9-37, Higashi-ohi 1-chome, Shinagawa-ku, Tokyo, 140-0011, Japan

Tel. : Head Office Tokyo (03) 3458-1111

Overseas Marketing Department. Tokyo (03) 3458-1115

Fax. : Tokyo (03) 3458-1163

URL <http://www.kato-works.co.jp>

C03251
 6.2011-1000 (AT) 1



We acquired the "ISO 9001" certification which is an international standard for quality assurance.